

LiFePO4

LITHIUM IRON PHOSPHATE

12V Series User Manual

- 📁 12.8V-50Ah
- 📁 12.8V-100Ah
- 📁 12.8V-100Ah Smart
- 📁 12.8V-100Ah-mini
- 📁 12.8V-100Ah-mini Smart
- 📁 12.8V-150Ah
- 📁 12.8V-150Ah Smart
- 📁 12.8V-200Ah
- 📁 12.8V-200Ah Smart
- 📁 12.8V-314Ah
- 📁 12.8V-314Ah Smart
- 📁 12.8V-628Ah
- 📁 12.8V-628Ah Smart



🌐 www.buknuwo.com

✉ gmail@buknuwo.com

PRODUCT MANUAL

Lithium Iron phosphate
(LiFePO₄) Battery



CAUTION & WARNING

Read and follow all safety instructions before handling, installing, or operating the battery. Failure to do so may result in fire, explosion, severe personal injury, or property damage.

Hazard Prevention Mandates

- To mitigate risks of fire, explosion, and burns, strictly adhere to the following:
- Do not short-circuit, crush, puncture, or disassemble the battery.
- Do not incinerate or expose the battery to excessive heat above 65°C (149°F).
- Do not immerse or expose the battery to water or moisture.
- Do not reverse the polarity during connections between the battery and charger or load.
- Avoid exposing the battery to direct flame, hazardous chemicals, or combustible materials.
- Avoid severe mechanical impact or vibration.
- Use only insulated tools when handling or connecting the battery.

Charging & Electrical Safety

- Do not exceed the maximum charging voltage of 15.0V.
- Charge only with a dedicated Lithium Iron Phosphate (LiFePO₄) charger set to 14.6V ± 0.2V.
- Do not connect batteries of different brands, chemistries, or models in series or parallel, as BMS incompatibility may lead to critical failures.

Prohibited Usage Environments

- Prohibited for use in environments with strong static electricity or powerful magnetic fields.
- Such exposure can interfere with or damage the Battery Management System (BMS), compromising safety protections and creating potential hazards.

Battery Disposal Protocol

- At end of life, insulate the terminals with insulating tape before disposal.
- Dispose of the waste battery at a designated recycling facility in accordance with local regulations. Do not dispose of in household waste.

APP Introduction

This application is developed and designed by Buknuwo®. It specializes in monitoring lithium batteries, providing real-time status readings such as the voltage, charging and discharging current, alarm prompts, protection status, etc. This allows users to clearly understand the status of lithium batteries and ensure safe use.



You can search "Buknuwo" in the App Store or Download via Customer Support

*This app only supports for smart batteries.

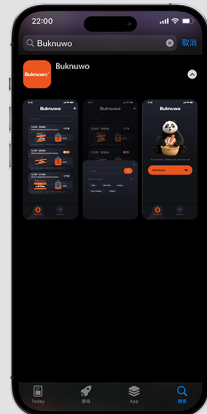

CONTENTS

Product Overview	01
Notice Before Using	02
Battery Parameters	03
Connection Steps	07
BMS Function Description	09
Charging Method	11
Cable Size	14
Application Examples	16
Warranty and Returns	17
FAQS	19



Key Features

1. Lithium Iron Phosphate (LiFePO₄) chemistry provides exceptional stability and consistent performance.
2. Advanced Battery Management System (BMS) ensures product safety and extended lifespan.
3. It supports fast charging and discharging with constant voltage full usable capacity at any state of charge Grade UL94V-0 (Fireproof).

External Features



NOTICE BEFORE USING

Please read the following important information carefully before installing and operating this product. Proper handling and maintenance are essential for ensuring battery performance, safety, and service life.

Initial State Information

To comply with transportation safety regulations, the battery is shipped with a State of Charge (SOC) between 30% and 50%. A full charge is recommended before initial use.

Electrical Connection Safety

When making connections, avoid direct contact between the positive and negative cable terminals to prevent short circuits, which can render the battery unusable or cause permanent damage.

It is strongly recommended to wrap all cable terminals with insulating tape during the wiring process to eliminate the risk of accidental short circuits.

Ensure the battery is correctly connected to the load/device. Reverse polarity connection is strictly prohibited.

System Compatibility & Operation

Before connecting the load, verify that the battery's rated output power can meet the peak power demand of the load to prevent overload conditions.

Long-Term Storage Guidelines

For extended storage (exceeding 3 months), charge the battery to approximately 50% SOC and store it in a dry environment between 10°C and 35°C (50°F to 95°F). To maintain battery health, recharge it every three months.

Important Safety Warnings

Do not disassemble the battery under any circumstances.

The battery is designed for upright installation with terminals facing upward. Do not install it upside down.

If your application requires lateral (side) mounting, you must contact our technical support team at gmail@buknuwo.com to confirm the specific orientation before proceeding.

BATTERY PARAMETERS

Content	12V50Ah	12V100Ah 12V100Ah Mini 12V 150Ah	12V200Ah	12V314Ah
Weight (lbs)	11.46	22.05/21.61/41.01	41.67	57.28
Dimensions (inch)	7.68*6.50*6.80	12.80*6.50*8.46/ 10.23*6.61*8.46/ 10.07*7.63*9.82/ (Nylon Handle)	21.06*8.07*8.46 (No Nylon Handle)	15.16*7.59*9.84 (No Nylon Handle)
Terminal Bolt Size	M8	M8/M8/M8	M8	M8
Rated Voltage	12.8V			
Shipping Capacity	50%			
Cycle Life	≥4000 cycles (to 80% capacity)			
Self Discharge Rate	<3%/month			
Series & Parallel Connections	4 Parallel(Max) 4Series(Max)			
Communication	Not Supported			
Case Material	ABS+PC/UL94-V0			
Pack Certifications	CE/UN38.3/Class 9/IEC62133/ROHS			
Cell Certifications	UL1642/UL2580/UN38.3			
Storage Temperature	-10~45°C (14~113°F)			
Recommended Discharge Current	0-35	0-60	0-150	0-150
Short Circuit Protection Current	630A	1700A	2800A	2400A

Capacity	12.8V 628Ah
Weight	48.9 kg (107.81lbs)
Dimensions (Nylon Handle)	25.19×9.64×8.86in / 64.0*24.5*22.5cm
Cell Type	Prismatic LiFePO4 Battery
Nominal Capacity	628Ah
Usable Capacity	628Ah
Nominal Voltage	12.8V
Energy	7680Wh
Terminal & Post Bolts	M8 (1.25mm Metric Thread)
Post Bolt Length	16mm
Charge Method	CC/CV (Constant Current /Constant Voltage)
BMS (Battery Management System)	250A Rated
Internal Impedance	≤40mΩ
Operating Temperature	Charging: 0°C to 50°C (32°F to 122°F) Discharging: -20°C to 60°C (-4°F to 140°F)
Storage Temperature	-10°C to 45°C (14°F to 113°F)
Charge Limit Voltage	14.6
Over-Charge Voltage Protection	14.6
Over-Charge Recovery Voltage	14.2

Content	12V50Ah	12V100Ah 12V100Ah Mini 12V 150Ah	12V200Ah	12V314Ah
Standard/Maximum Continuous Charging	10A/50A	20A/100A	40A/200A	60A/200A
Max continues Discharging Current	50A	100A	200A	200A
Energy	640	1280	2560	4019.2
Rated Capacity	50	100	200	314
Maximum Power	640	1280	2560	2560
Over-charge Voltage Protection	14.6+0.1V			
Over-charge Voltage Protection Release	14.2+0.1V			
Over-discharge Voltage Protection	9.2+0.12V			
Over-discharge Voltage Protection Release	10.8+0.12V			
Over-current Discharge Protection	150±50A	450±50A	700±100A	600A
Over-current charge Protection	70+10A	130+30A	350+50A	350+50A
Recommended Charging Current	0-15	20-50	20-50	50-100
Maximum Continuous Charging Current	50	100	200	200
Short Circuit Current Protection	Support			
Release Condition	Cut Load			

Charging High Temperature Protection	149+41°F
Discharging High Temperature Protection	158+41°F
High Temperature Protection Release Condition	Drop by 50+41°F
Charging Low Temperature Protection	32+41°F
Discharging Low Temperature Protection	-4+41°F
Temperature Protection Release Condition	Rise by 50+41°F
Communication	Not supported
Case Material	ABS Plastic
Shipping SOC	40%
Shipping Voltage	13.1-13.2V
Charge Limit Voltage	14.6
Recommended Charging Voltage	14.6

Recommended Charge Current	50-100
Recommended Discharge Current	0-150
Max. Continuous Charge Current	250A
Max. Continuous Discharge Current	250A
Maximum Power Output	2560
Over-Discharge Protection Voltage	9.2
Over-Discharge Recovery Voltage	10.8
Discharge Over-Current Protection	800(± 200A)
Short Circuit Protection Current	2500
Recommended Charging Voltage	14.6
Shipping Voltage	13.1~13.2V
Shipping SOC	40%
Cycle Life	≥4000 cycles (to 80% capacity)
Self-Discharge Rate	<3% per month
Communication	Not supported
Case Material	ABS Plastic
Pack Certifications	CE/UN38.3/Class 9/IEC62133/RoHS
Cell Certifications	UL1642/UL2580/UN38.3
Storage Temperature	-10~45°C (14~113°F)
Series & Parallel Connections	4 Parallel(Max) 4Series(Max)

(Other lengths of M8 bolts can be used instead according to actual needs).

Battery Management System (BMS) Specifications

State of Charge	Voltage	Technical Notes
100%	13.5V	Full charge voltage (BMS cutoff)
99%	13.45V	Near-full charge float voltage
80%	13.40V	High SoC operating range
70%	13.30V	Standard working voltage
40%	13.23V	Mid-discharge voltage
30%	13.18V	Recommended recharge threshold
20%	12.90V	Low voltage warning zone
10%	12.80V	Deep discharge limit
1%	☆10.8V	Critical low-voltage disconnect
10%	9.5V	Absolute minimum (cell damage risk)

CONNECTION STEPS

STEP 01

- Fully charge each battery individually.

STEP 02

- Let the batteries rest for 15 minutes → Verify each battery voltage $> 13V$.

STEP 03

- Connect the batteries in series or parallel.

(Note: Only batteries of the same model/specs can be connected.)

Parallel Connection

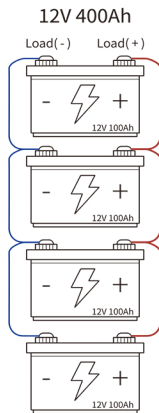

Series Connection

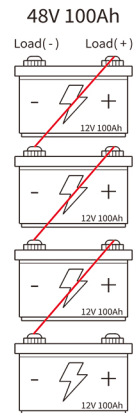

Max. connect in series & Parallel (4S4P)

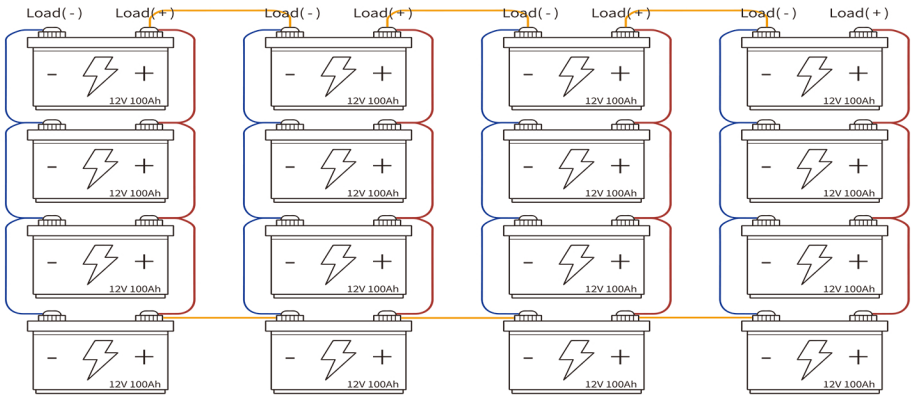

01
STEP

Overcharge Protection ($>14.6V$)

- The BMS instantly stops charging if any cell voltage exceeds the safety limit.

02
STEP

Over-Discharge Protection ($<10V$)

- Discharging is automatically halted when battery voltage drops below 10V.
- Auto-Recovery: The system reactivates after 15 seconds if voltage recovers to $>11.8V$.

03
STEP

Temperature Protection

- **High-Temperature Cutoff:**
Charging is disabled at $\geq 65^{\circ}C$ ($149^{\circ}F$).
Discharging is disabled at $\geq 70^{\circ}C$ ($158^{\circ}F$).
- **Low-Temperature Cutoff:**
Charging blocked at $\leq 0^{\circ}C$ ($32^{\circ}F$).
Discharging supported down to $-20^{\circ}C$ ($-4^{\circ}F$).

04
STEP

Over current/Short-Circuit Protection

- **Triggers full output disconnection.**
- **Recovery Steps:**
Disconnect ALL battery cables.
Check voltage with a multimeter:
 $>11.8V$: Reconnect to restart.
 $\leq 10.8V$: Contact gmail@buknuwo.com for support.

Cell Balancing Function Description

Activation Requirements

The passive cell balancing circuit is automatically activated when both of the following conditions are met during the charging process:

The battery enters the constant-voltage (absorption) charging stage (typically above 95% State of Charge).

The total system voltage exceeds 14.1V.

Operation Methodology

The integrated Battery Management System (BMS) continuously monitors the voltage of each individual cell.

Using precision shunt resistors, the circuit intelligently dissipates excess energy as heat from any cell with a higher voltage than its neighbors.

This process equalizes the State of Charge (SOC) across all cells in the pack, maintaining a tight voltage tolerance within $\pm 1\%$.

Performance Benefits

◆ Optimized Performance & Efficiency

Maintains an ultra-low cell voltage differential of $<30\text{mV}$.

Ensures maximum usable capacity and stable power output.

◆ Extended Service Life

Prevents the premature aging and capacity degradation caused by chronic overcharging of individual cells.

Mitigates cell-to-cell performance divergence, thereby prolonging the overall battery pack lifespan.

◆ Enhanced Safety & Reliability

Enforces a strict maximum voltage limit of 3.65V per cell during the balancing process.

Acts as a critical safeguard against overcharge conditions, contributing to the long-term safety of the battery system.

You can charge your lithium iron phosphate batteries whenever you want, just like your cellphone. Unlike lead-acid batteries, lithium iron phosphate batteries do not get damaged if they are left in a partial state of charge, so you don't have to stress about a memory effect, and you don't have to drain them completely before charging.

Battery Charger(mains power)

- The most ideal way to charge a LiFePO4 battery is with a lithium iron phosphate battery charger, as it will be programmed with the appropriate voltage limits. Most lead-acid battery chargers will do the job just fine.
- A 12V lithium battery at 20% capacity will hold voltage around 13V, while its lead-acid battery will be approximately 11.8V at the same capacity. So if you use lead-acid charger to charge your lithium battery, it may not be fully charged.

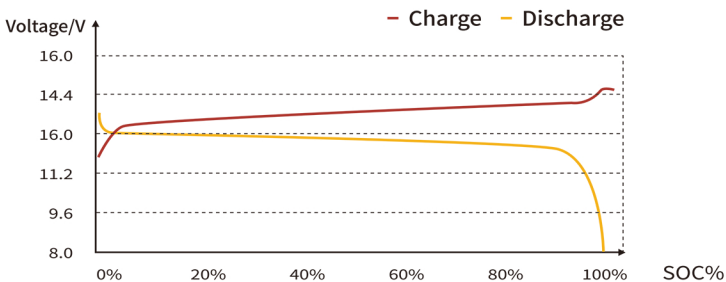

Sample: 12V50Ah battery

Environmental conditions required for all tests: $77 \pm 9^\circ\text{F} / 25 \pm 5^\circ\text{C}$

1. LiFePO4 Battery Charging Phases:

- CC (Constant Current) Phase (T1)

During the initial charging stage, a depleted battery receives a constant current while the voltage steadily rises until it reaches the predefined constant voltage threshold, which varies depending on the charging method.

- CV (Constant Voltage) Phase (T2)

Once the constant voltage is achieved, the charging current gradually decreases until it reaches the tail current level (0.02C, e.g., 12A for a 600Ah battery). The charging process is automatically terminated when this tail current is reached, signifying a full charge.

Note: Tail current (A) = Battery capacity × 0.02C.

*Example: $628\text{Ah} \times 0.02\text{C} = 12.56\text{A}$ tail current.

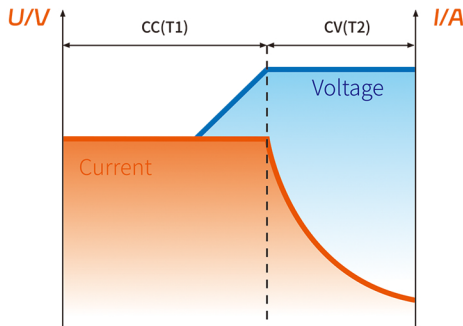

LiFePO4 Battery charging curve

2. Lead-Acid Battery Charging Phases:

- Bulk/Boost Phase (T1)

In this phase, the battery is charged at the maximum current until the absorption voltage setpoint is achieved.

The voltage increases steadily during this period.

This phase corresponds to the CC phase in LiFePO₄ battery charging.

- Absorption Phase (T2)

Once the absorption voltage is reached, the voltage remains constant, while the current gradually decreases as the battery approaches full charge (90-95% SOC). is nearly full (90-95% SOC).

This phase typically lasts no longer than 3 hours to prevent overcharging.

This phase corresponds to the CV phase in LiFePO₄ battery charging.

- Float Phase (T3)

After absorption, the voltage is lowered to a float voltage to maintain the battery at a safe level without overcharging.

The current is minimized, compensating only for the battery's self-discharge.

If a significant discharge occurs, the charger may return to Bulk/Boost or Absorption to restore energy.

This phase is not applicable to LiFePO₄ batteries.

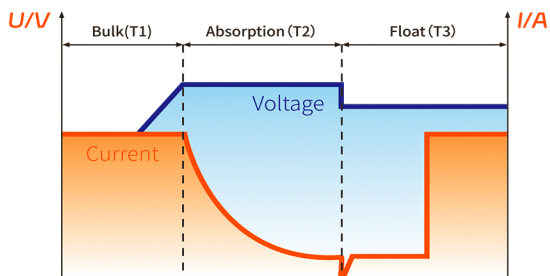

Lead Acid Battery charging curve

GENERAL STEPS

If the battery has been disconnected by the BMS due to a protection trigger, please follow these reactivation steps:

STEP 01

- **Disconnect** all loads and chargers from the battery terminals.

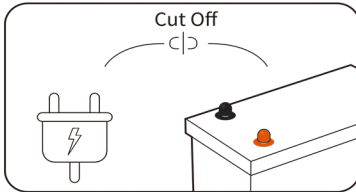

STEP 02

- Allow the battery to rest for at least **30** minutes.

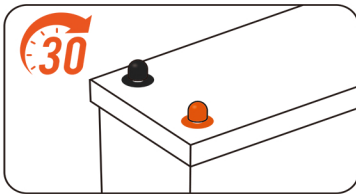

STEP 03

- Automatic recovery will occur when voltage stabilizes above **11.8V**.

STEP 04

- Fully recharge the battery before returning it to normal use.

Cable size should be selected based on the expected load.

Refer to the table below for the amperage of copper cables of different sizes.

Cable Specification and Capacity(AWG/MM2)	Current Capacity(A)
14(2.08)	20
12(3.31)	25
10(5.25)	35
8(8.36)	50
6(13.3)	65
4(21.1)	85
2(33.6)	115
1(42.4)	130
1/0(53.5)	150
2/0(67.4)	175
4/0(107)	230

Optimal Battery Configuration Guidelines.

For optimal performance and safety when connecting multiple batteries, please adhere to the following requirements:

Brand Consistency

1. Use only Buknuwo LiFePO4 batteries.
2. Do not mix with other brands due to potential BMS compatibility issues.

Battery Chemistry

1. Exclusive LiFePO4 chemistry is required.
2. Never combine with other battery types (Li-ion, SLA, AGM, etc).

Voltage Specifications

1. All batteries must be 12V nominal.
2. It is recommended to fully charge all units before connection.

Capacity Matching

All connected batteries must have identical Ah ratings.

Age Synchronization

1. Maximum 3-month age difference between batteries.
2. New and old batteries should not be combined.

APPLICATION EXAMPLES

Intended Use Cases

This battery is engineered for deep-cycle applications in a wide range of scenarios, including but not limited to:

Outdoor Recreation & Mobile Living

- Recreational Vehicles & Camper Vans
- Marine & Boating Electronics (e.g., Trolling Motors, Fish Finders)
- Overlanding & Off-Grid Power Systems

Industrial & Commercial Use

- Telecommunications Backup Power
- Floor Cleaning Machines & Industrial Equipment
- Material Handling Equipment
- UPS & Emergency Lighting Systems

Direct Replacement

- A drop-in upgrade for 12V Lead-Acid, AGM, or Gel batteries in existing systems.

IMPORTANT: NOT SUITABLE FOR ENGINE STARTING

This battery is not designed for cranking gasoline or diesel engines. Its BMS is configured for sustained discharge, not the instantaneous high-current surge required for engine starting.



Warranty Exclusions:

The manufacturer's warranty does not cover:

Installation & Usage Related

1. Improper installation, use, maintenance, or servicing.
2. Insufficient or improper fastening of battery components.
3. Loose terminal connections.
4. Reverse polarity connections.
5. Electrical system malfunctions causing battery failure.
6. Use with unauthorized third-party products.
7. Product modifications without manufacturer's written approval.
8. Applications exceeding design specifications (including repeated engine starts or exceeding rated discharge current).

Configuration & Connections

1. Series connections exceeding **4 batteries** (>48V systems).
2. Parallel connections exceeding **4 batteries**.
3. Short circuits (accidental, intentional, or unintentional).
4. High resistance from corroded terminals, poor crimping, or undersized cables.

Physical & Environmental Damage

1. Impact, collision, or drop damage.
2. Improper storage conditions.
3. Force majeure events (fires, natural disasters, etc).

Maintenance & Charging

1. Improper charging (under/overcharging per manual specifications).
2. Batteries left uncharged for over **12 months**.
3. Commercial applications with $\geq 80\%$ daily depth of discharge.
4. Failure to follow recommended charging protocols.

General Conditions

1. Any damage resulting from user negligence or failure to follow safety guidelines.
2. Consequences of product misuse or improper operation.

All warranty claims are subject to manufacturer's inspection and approval. Proper installation and maintenance as specified in the user manual are required to maintain warranty coverage.

Warranty and Returns

After-Sales Support

1. For any product support needs, please contact our service team at: gmail@buknuwo.com.
2. Our technical specialists will provide prompt assistance.

Battery Storage Guidelines

1. For optimal storage:
Charge the battery to approximately **50%** capacity.
Disconnect all loads by removing the negative terminal connection.
Store in a temperature-controlled environment (ideal: **25°C/77°F**).
2. Storage Characteristics:
Typical self-discharge rate: **<3%** per month (at **25°C/77°F**).

Note: Discharge rates may increase significantly under extreme environmental conditions.

FREQUENTLY ASKED QUESTIONS

Q1: My battery shows 0V and has no output. What is the cause and solution?

A: A 0V reading typically indicates that the Battery Management System has activated protection due to over-discharge, short-circuit, or over-current.

Please follow this systematic troubleshooting guide:

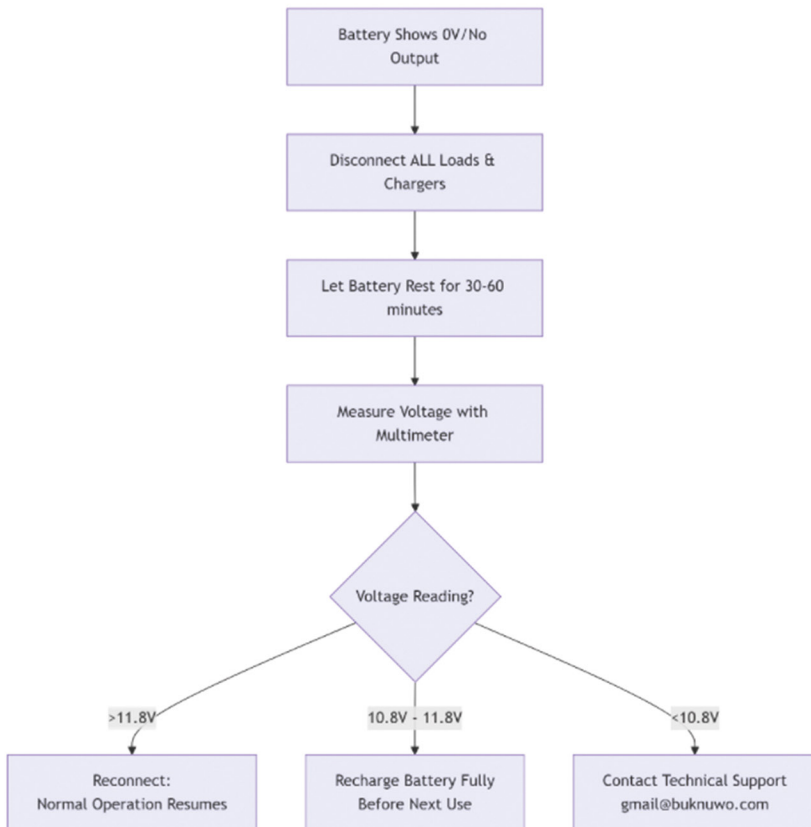

Q2: Is initial charging required before first use?

A: Yes, it is mandatory to fully charge the battery before its first operation. This ensures the cell chemistry is properly activated and the State of Charge is calibrated. This requirement is equally critical when configuring new batteries in series or parallel.

Q3: What is the proper method to verify battery voltage?

A: For an accurate state-of-charge assessment, use a digital multimeter:

Set the multimeter to DC Voltage (V⁻) mode.

Connect the red probe to the positive (+) terminal and the black probe to the negative (-) terminal.

A reading of approximately 13.3V to 13.5V indicates a fully charged battery.

Q4: What are the installation orientation requirements?

A: Our batteries are designed for flexible mounting and can be installed in any orientation (upright, on its side, etc.), provided the terminals are: Properly secured to the specified torque to prevent arcing or overheating.

Protected from accidental contact with conductive materials or moisture to prevent short circuits.

Q5: What conditions will trigger the Over-Discharge Sleep of the battery?

A:

- Sleep Mode 1: Over-Discharge Sleep

Sleep Condition: Sleep is triggered if cell over-discharge or overall

over-discharge is not resolved within 30 seconds. Wake-up Condition:

Wake-up by charging.

- Sleep Mode 2: Command Sleep

Sleep Condition: Sleep is triggered by a command (from upper computer or Bluetooth software). Wake-up Conditions: Wake-up by charging, wake-up by discharging, wake-up by Bluetooth communication, automatic wake-up.

- Sleep Mode 3: Idle Sleep

Sleep Condition: Sleep is triggered if the battery remains static for 24 hours with no current, no communication, no Bluetooth connection, and the minimum cell voltage is above 3V. Wake-up Conditions: Wake-up by charging, wake-up by discharging, wake-up by Bluetooth communication, automatic wake-up.

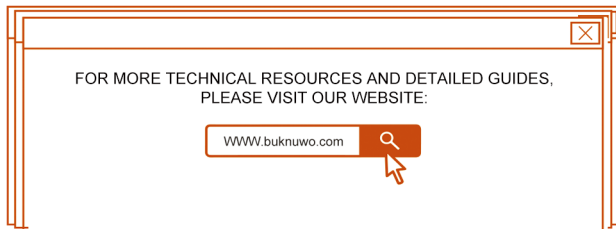

A Heartfelt Thank You for Choosing Buknuwo

Dear Valued Customer:

We extend our deepest gratitude for the trust you have placed in Buknuwo Batteries. Your unwavering support serves as a constant inspiration, driving our team to pursue innovation and deliver state-of-the-art battery solutions, all while maintaining an uncompromising commitment to service excellence.

It is through your invaluable feedback and the relentless dedication of our team that we are able to provide superior products at competitive prices, ensuring your complete satisfaction. Your confidence in our brand fuels our passion to continually raise the standard in energy solutions.

We take immense pride in the engineering and craftsmanship of our products and sincerely hope they exceed your expectations. Should you require any assistance, our dedicated team remains readily available to support you.

With sincere appreciation,
The Buknuwo Team

Buknuwo®

 www.buknuwo.com

 gmail@buknuwo.com